

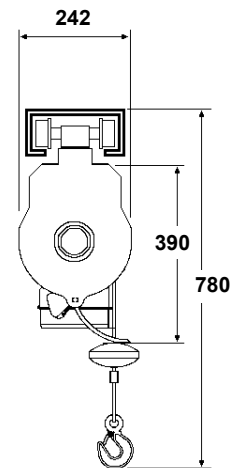

BETA 300 GANTRY HOIST

HOIST SPECIFICATIONS	
Payload	300kg
Maximum Lifting Height	30m
Speed	20m/min
Voltage	110V single phase
Power Cont. Duty	1.9kW
Power Consumption	3.52kVA
Power Supply Fuses (HRC)	32A
Unit Weight	48kg
Installation Type	
Static	✗
Scaffold Winch	✗
Runway Beam	✓
Ground Based	✗

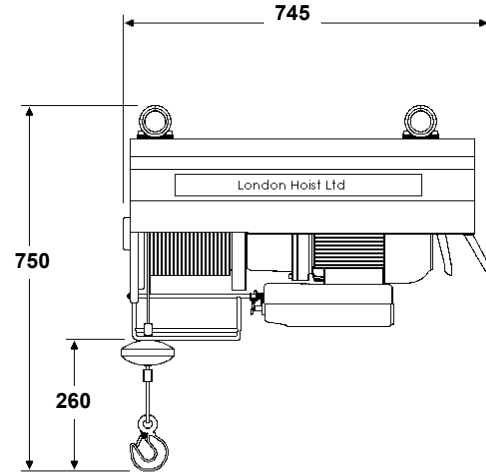

Accessories Available from London Hoist

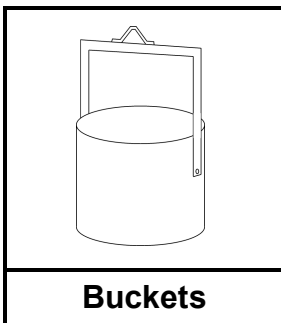

Buckets

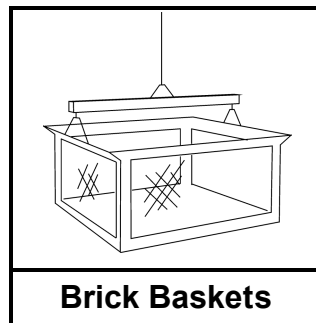

Brick Baskets

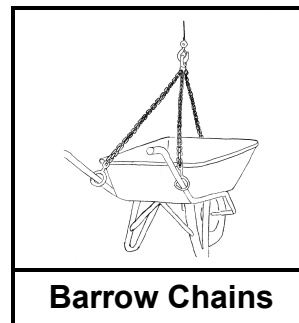

Barrow Chains



Webbing Slings



LONDON
HOIST
LTD

43 London Road - Stanford Rivers - Ongar - CM5 9PJ
TEL : 0207 5384833 - FAX : 0207 5153593
www.londonhoist.co.uk - info@londonhoist.co.uk