

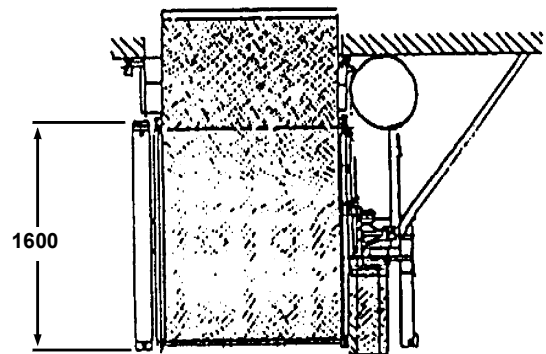

MABER 500 GOODS HOIST

HOIST SPECIFICATIONS	
Capacity	500kg
Internal Cage Length	1.5m
Internal Cage Width	1.3m
Speed	25m/min
Voltage	415V 3 Phase
Power Cont. Duty	3kW
Power Supply Fuses (HRC)	32A
Base Unit Weight	440kg
Max. Freestanding Landing Height	n/a
Max. Tie Interval	6m
Max. Tie Oversail	4.5m
Max. Final Landing Height	100m
Mast Section Length	1.5m
Scaffold Tower Size Required	2.4m x 2.4m

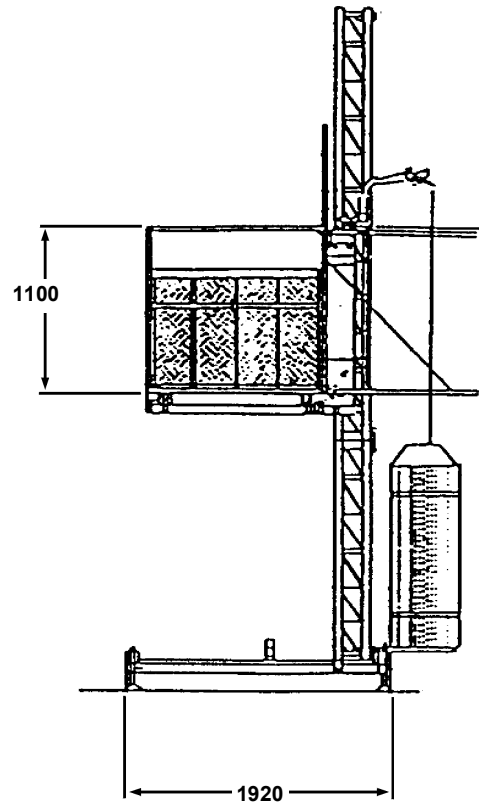

LONDON
HOIST
LTD

43 London Road - Stanford Rivers - Ongar - CM5 9PJ
TEL : 0207 5384833 - FAX : 0207 5153593
www.londonhoist.co.uk - info@londonhoist.co.uk

04-2003