

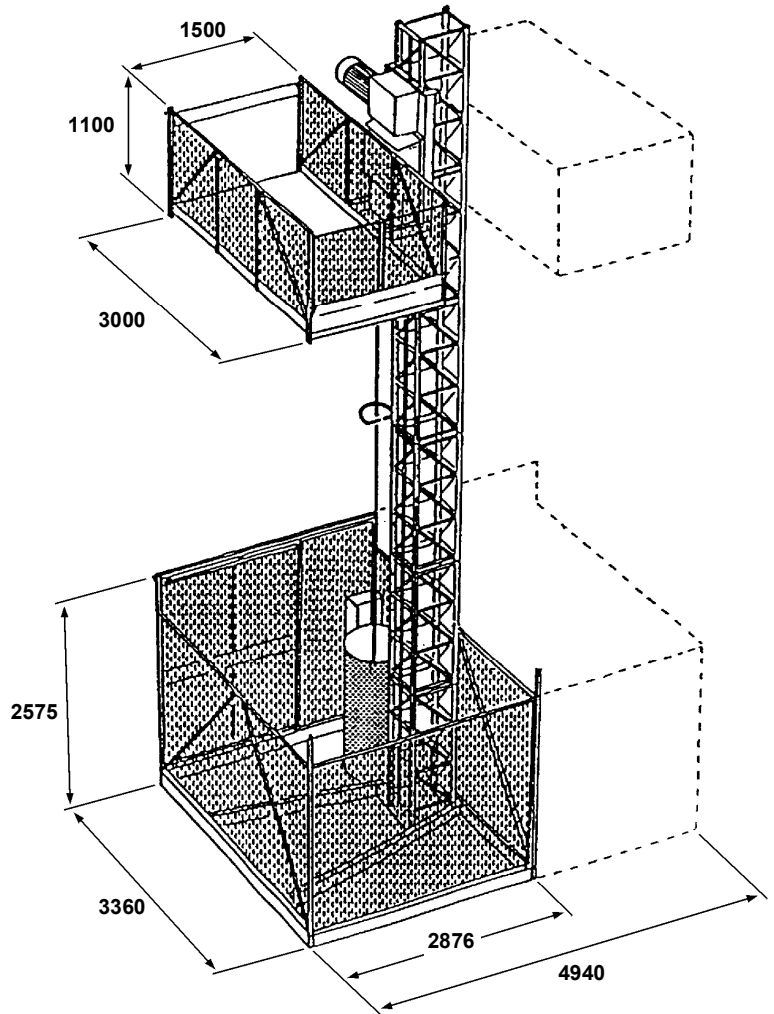

WICKHAM G1200HD GOODS ONLY PLATFORM HOIST

HOIST SPECIFICATIONS	
Capacity	1200kg
Internal Cage Length	3.0m
Internal Cage Width	1.5m
Speed	28m/min
Voltage	415V 3 phase
Power Cont. Duty	11kW
Starting Current	135A
Power Consumption	18kVA
Power Supply Fuses (HRC)	50A
Base Unit Weight	2305kg
Max. Freestanding Landing Height	7.5m
Max. Tie Interval	9m
Max. Tie Oversail	9m
Max. Final Landing Height	98m



43 London Road - Stanford Rivers - Ongar - CM5 9PJ
TEL : 0207 5384833 - FAX : 0207 5153593
www.londonhoist.co.uk - info@londonhoist.co.uk